

technical data sheet

pakrol® range Skates and trolley skates

réf. : **T 2060 GB**
rév. n° :
date : **03/02**
page : **1/1**

Function :

The pakrol range has been designed to handle and move heavy and rigid loads manually on a flat and resistant floor.

Description and principle of use :

To offer the best stability of the load and make its guiding easier, we recommend to share the load surface on 2 skates and 1 trolley skate (refer to the undermentioned sketch).

Distribution of the load :

Total load	Trolley skate	Skate
8 t	4 t	2 x 2 t
12 t	4 t	2 x 4 t
14 t	6 t	2 x 4 t
18 t	6 t	2 x 6 t
20 t	8 t	2 x 6 t

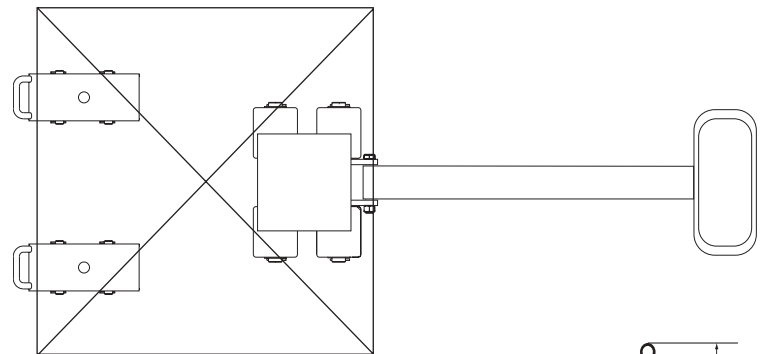

Advantages :

- Robust frame.
- Minimum maintenance.
- Nylon wheels with ball bearing (except 8 t trolley skate with PU wheels).
- Handle for transport.
- Trolley skate load plate with ball thrust bearings.

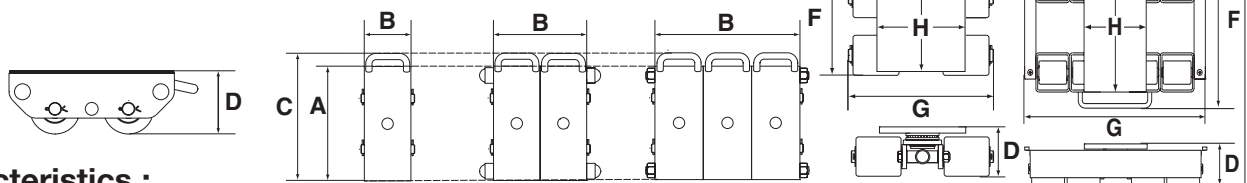

Characteristics :

W.L.L.	Skate 2 t	Skate 4 t	Skate 6 t	Trolley skate 4 t	Trolley skate 6/8 t	
Weight (kg)	5	11	25	14	50	
Operating temperature range (°C)	-10 à +30 °	-10 à +30 °	-10 à +30 °	-10 à +30 °	-10 à +30 °	
Dimensions (mm)	A	270	270	-	-	
	B	106	232	-	-	
	C	308	308	-	-	
	D	110	110	110	110	110
	E	-	-	-	940	1200
	F	-	-	-	230	530
	G	-	-	-	297	640
	H	-	-	-	145 x 180	400 x 220