

# Battery drill winch DW1000

1000 kg

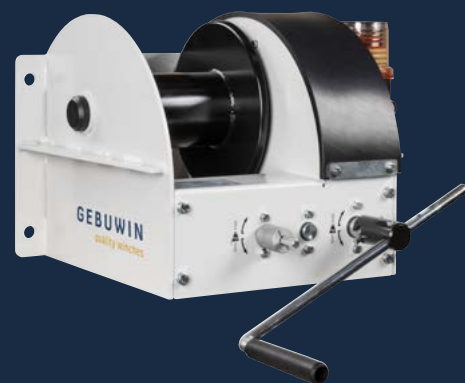

## Description of the winch

The worm gear winch can be operated both manually and with a cordless drill. A user-friendly winch and often used as a back-up system. If there is a power failure and you want to move a heavy load quickly and effectively, the use of a battery-powered drill offers a solution. The winch is equipped with automatic grease lubrication and a special flexible adaptor to absorb the vibrations of the drilling machine and keep the winch in good condition.

## Product specificaties

- > winch suitable for lifting and pulling in compliance with EN13157
- > static safety factor 4
- > load pressure brake with double ratchet system for safe stable hold of the load in any position
- > cable outlet upwards, downwards or at rear
- > protection classification IP54
- > automatic grease system for the worm gearing
- > adjustable crank
- > drill and hand operated
- > suitable for wall and (optional) floor mounting
- > 1 layer of paint

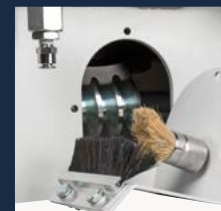

## Options (code)

- zinc-plated finish 6 - 8 micron (EV)
- 2 layers of paint (2L)
- grooved drum (GD)
- 2 drum compartment (2D) or multiple up to 8 (XD)
- suitable for floor mounting (FM)
- custom options possible - [on request](#)

## Accessories

- steel, stainless steel or fiber rope ([p. 57](#))
- pulley block ([p. 59](#))



[Product & instruction video on YouTube](#)

**GEBUWIN**  
quality winches

Industrieweg 6, 7102 DZ Winterswijk, The Netherlands  
Telephone: +31(0)543 532600 Email: [info@gebuwin.com](mailto:info@gebuwin.com)

For more information, visit: [www.gebuwin.com](http://www.gebuwin.com)

## Technical specifications DW1000

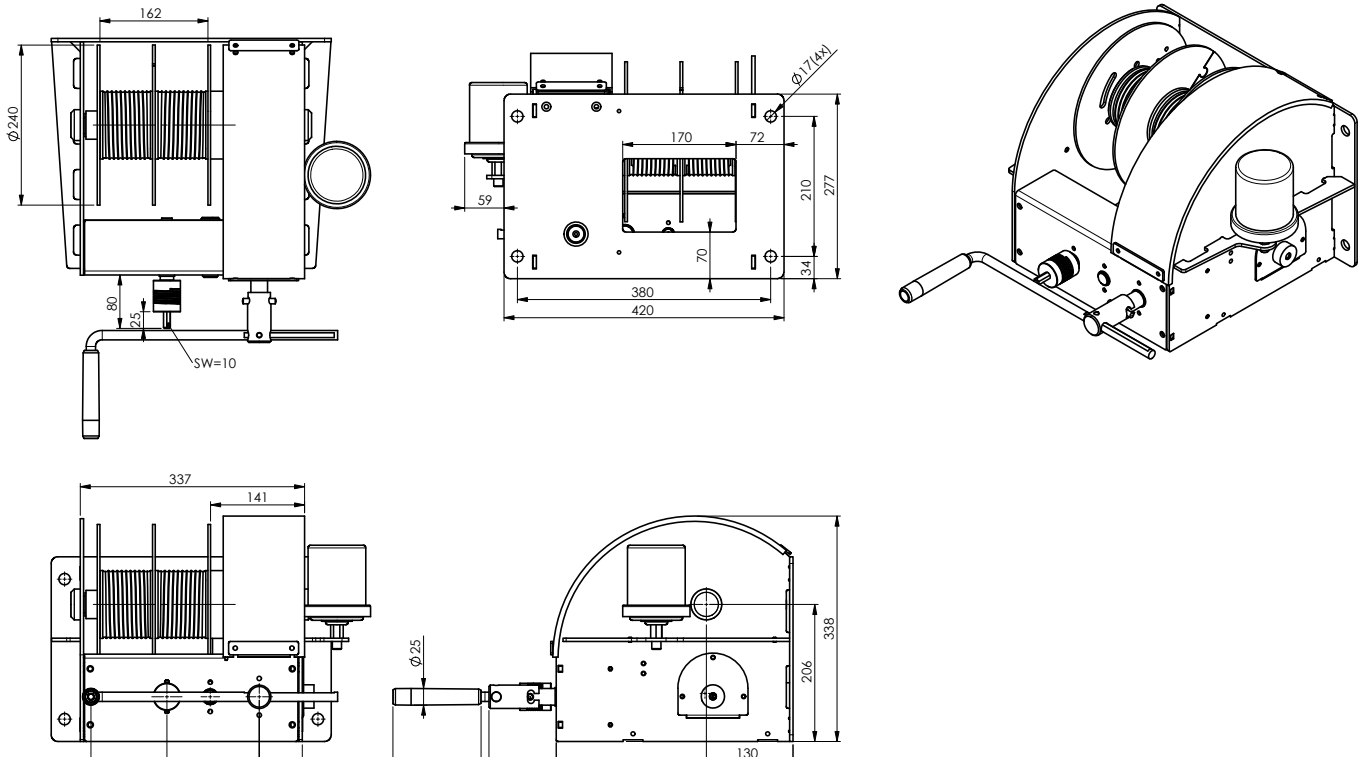

Technical specifications	Unit	DW1000
Capacity 1st layer	kg	1000
Capacity 4th layer	kg	725
Capacity top layer	kg	527
Rope diameter- $\varnothing$	mm	8
MBL of cable	kN	30
Rope storage 1st layer	m	5,5
Rope storage 4th layer	m	29,2
Rope storage top layer	m	73
Lifting speed	m/min	0,5
Crank effort at full load	kg	11
Torque ingoing shaft	Nm	6
Max. input rotation speed drill	rpm	650
Weight (without rope)	kg	39
Article number	no.	77290005