



▶ Capacity from 250 to 1500 kg.
 Range of travel trolleys allowing the use of TRBoxter compact electric winches range on jib cranes or on IPE, IPN, HEB type rails...

- ▶ Push trolley or single speed electric trolley depending on model.
- ▶ 400V-50Hz three phase power.
- ▶ Upper limit switch fork and counter weight included.
- ▶ Pendant control (Lifting, Translating), removable (3 m long control cable).

Options ▶ Wire rope (m/l or kit) and hook (see p. 94-98).
 ▶ Travel limit switch.
 ▶ Power feeding line.

Strong points

- ▶ HUCHEZ counterweight included.
- ▶ Pendant control with lifting and translating functions.



▶ Push trolley model.

Dimensions

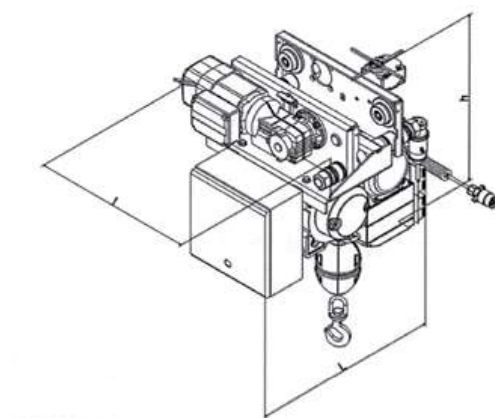

▶ Electric trolley.

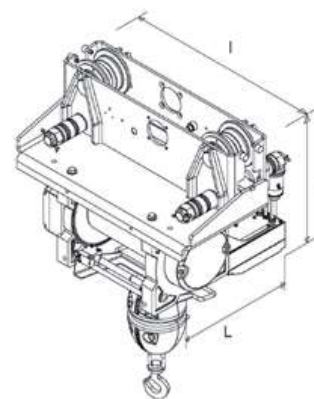

▶ Push trolley.

Applications



▶ Lifting and translating a load in a zoo.

Models	Chariot BOX0.5 L	Chariot BOX1.5 L	Chariot BOX0.5 E	Chariot BOX1.5 E
Lost headroom mm	760	915	760	915
L x l x h mm	545 x 550 x 575	400 x 610 x 750	585 x 550 x 575	600 x 610 x 750

Technical characteristics

References	Chariot BOX0.5 L	Chariot BOX1.5 L	Chariot BOX0.5 E	Chariot BOX1.5 E
Capacity kg	500	1500	500	1500
Winch range	TRBoxter 250-500 (standard or long drum)	TRBoxter 600-1500 (standard or long drum)	TRBoxter 250-500 (standard or long drum)	TRBoxter 600-1500 (standard or long drum)
Type of trolley	Push trolley		Electric	
Beam width mm	60-250	75-250	60-250	75-250
Trolley speed m/min	-	-	20	14
Total mass (winch included) kg	116	204	136	224