

## STW-F Steel jacks acc. to DIN 7355 with fixed lifting claw

Capacity 1500 - 10000 kg

Steel jacks are traditional hoisting equipment for universal application in the forest and agricultural sector, in the industrial sector for assembly activities and many other fields of application.

### Features

- The robust steel design and a toothed rack of solid material increase the service life of the jack.
- Low wear owing to hardened gearing parts and precisely machined teething.
- The precisely machined gears with a high degree of efficiency guarantees low crank forces.
- The load is supported either on the claw or the head of the steel jack.
- Robust base plate for a high level of stability.
- No reduction of capacity on the claw.



Model STW-F  
with fixed lifting claw  
and Sifeku

### Technical data STW-F Siku

Model	Art.-No. Siku	Capacity kg	Height A mm	Lift <sup>1</sup> mm	Hand effort at WLL daN	Weight kg
STW-F 15	40021975	1500	720	350	28	12
STW-F 30	40021984	3000	720	350	28	21
STW-F 50	40051705	5000	720	300	28	26
STW-F 100	40051707	10000	792	300	40	42

<sup>1</sup>Height of lift = Height + Lift

### Technical data STW-F Raku

Model	Art.-No. Raku	Capacity kg	Height A mm	Lift <sup>1</sup> mm	Hand effort at WLL daN	Weight kg
STW-F 15	40022008	1500	720	350	28	12
STW-F 30	40022013	3000	720	350	28	21
STW-F 50	40022019	5000	720	300	28	26
STW-F 100	40051708	10000	792	300	28	42

<sup>1</sup>Height of lift = Height + Lift

### Dimensions STW-F

Model	STW-F 15	STW-F 30	STW-F 50	STW-F 100
A, mm	720	720	720	792
B, mm	130	130	145	145
C, mm	140	140	155	155
D, mm	90	90	110	125
E, mm	50	50	68	80
F, mm	60	61	62	85
G, mm	60	65	70	85
N, mm	250	250	250	300

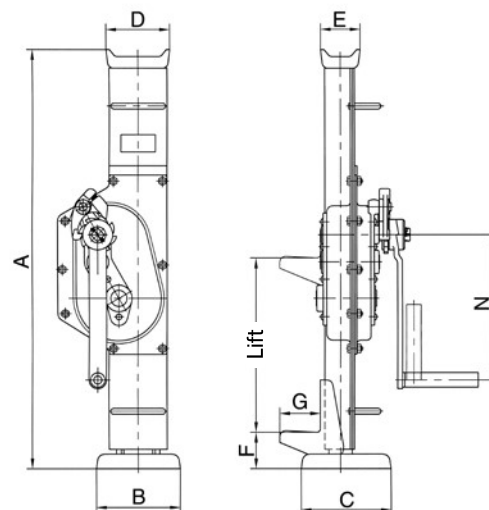

## INFO

STW-F Sifeku on request.